

SPECIFICATIONS FOR OCI-PTH

GENERAL DIMENSIONS:

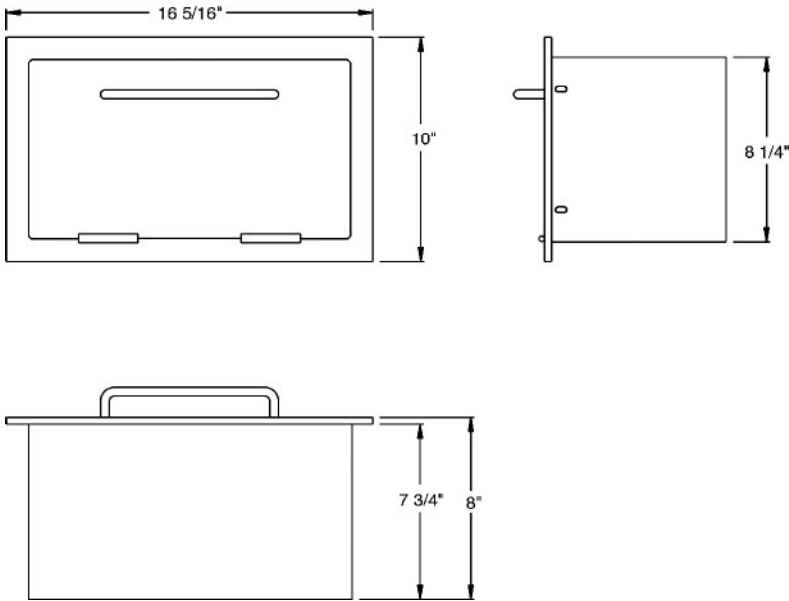

CUTOUT DIMENSIONS FOR BUILT IN APPLICATION:

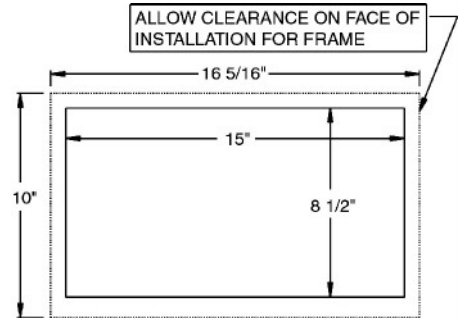

Standard Features

- 304 Non-rusting and Non-magnetic stainless steel construction.
- Positive staying door latch for animal prevention.
- Easy installation with hardware provided.
- Fully Assembled.

Warranty

- 1-Year Full replacement Warranty on all components due to manufacturer defects in craftsmanship.
- 5-Year Warranty on all Stainless Steel Parts.

Stainless Steel paper towel holders are covered for 1 full year from date of purchase, and 5 full years on all stainless steel parts only by defects in workmanship. A copy of the original receipt is required for all warranty claims. Please keep a copy of this handout along with original receipt for your files.

- Shipping weight of OCI-PTH (15 lbs.)

PLEASE NOTE:

*Because of continuing product improvement these specifications are subject to change without notice.