

SPECIFICATIONS FOR OCI-SSTC26X18 TIP OUT TRASH CAN

GENERAL DIMENSIONS:

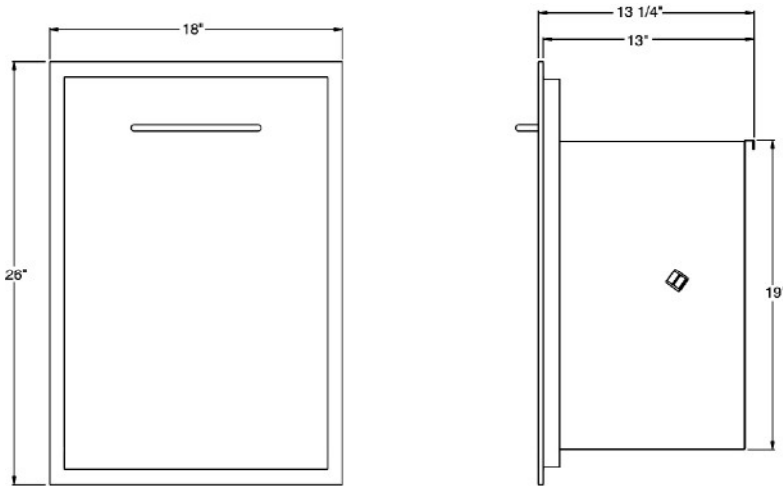

CUTOUT DIMENSIONS FOR BUILT IN APPLICATION:

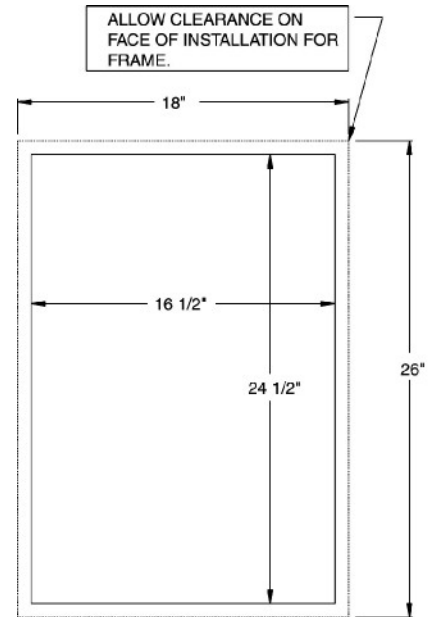

Standard Features

- 304 Non-rusting and Non-magnetic stainless steel construction.
- Tip out design for easy access.
- Fully Assembled.
- Uses common sized trash bags.

Warranty

- 1-Year Full replacement Warranty on all components due to manufacturer defects in craftsmanship.
- 5-Year Warranty on all Stainless Steel Parts.

Stainless Steel Trash cans are covered for 1 full year from date of purchase, and 5 full years on all stainless steel parts only by defects in workmanship. A copy of the original receipt is required for all warranty claims. Please keep a copy of this handout along with original receipt for your files.

- Shipping weight of OCI-SSTC26x18 (65 lbs.)

PLEASE NOTE:

*Because of continuing product improvement these specifications are subject to change without notice.